

REY2575

ADJUSTABLE HEIGHT WORKSTATION

www.reytek.com

304 STAINLESS STEEL CONSTRUCTION

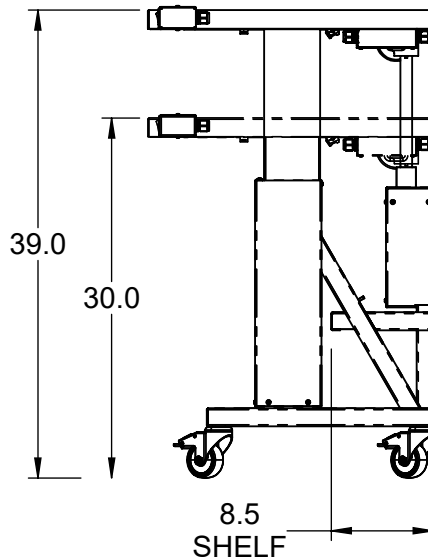
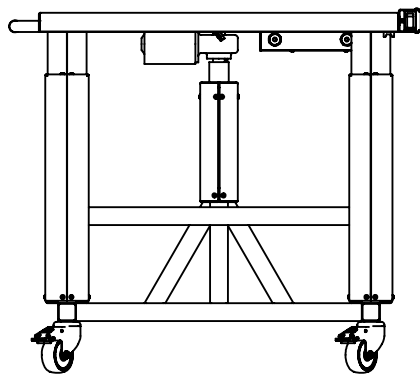
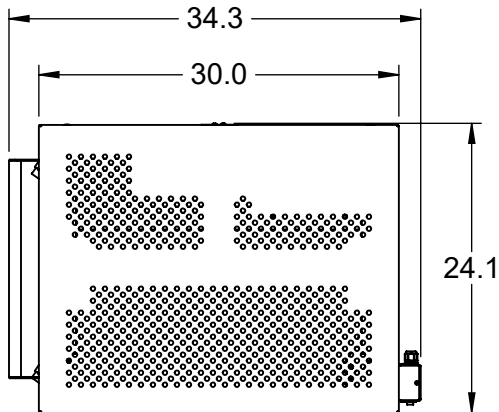
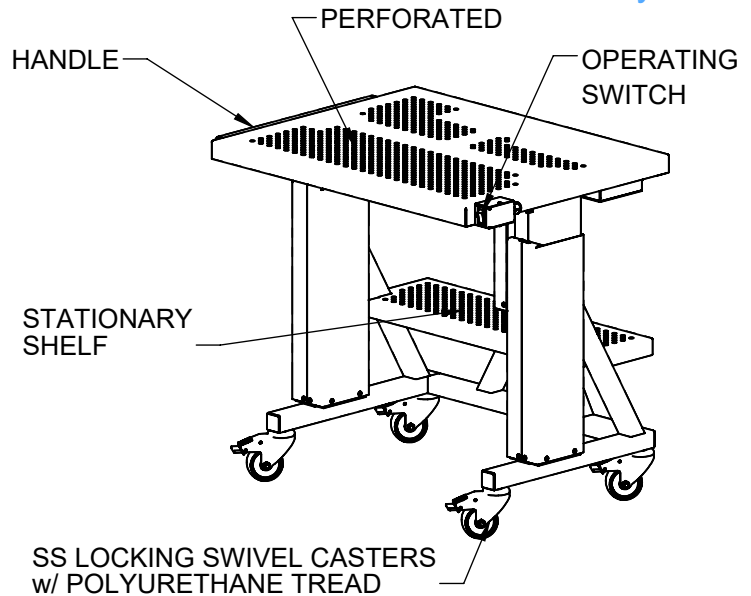

NOTES:

- 1: 120VAC ELECTRIC OPERATION.
2. NO DANGEROUS PINCH POINTS, MUCH SAFER THAN SCISSOR TYPE LIFTING.
3. HEAVY DUTY CONSTRUCTION.
4. INFINITELY ADJUSTABLE.